



Port Mann/Highway 1 Project

Transportation Investment Corporation

File: CN 1109

March 23, 2011

Dear Commercial Vehicle Operators:

Re: Lane Width Restriction on Highway 1 during PMH1 Improvement Project Construction

The Port Mann/Highway 1 Improvement Project together with the Commercial Vehicle Safety and Enforcement office would like to ensure that commercial vehicle operators are aware that while the PMH1 Improvement Project is underway, there will be restrictions for truck loads that are wider than 3.8 metres. The PMH1/Highway 1 corridor between the Cassiar Tunnel in Vancouver and 216 Street in Langley is considered an active construction zone, and commercial vehicle operators should be aware that in certain areas, Highway 1 lanes may be more narrow than usual.

To ensure the safety of commercial vehicle operators and the travelling public, please be aware of the following:

- Lane widths can be restricted to 3.8 metres (12.47 Feet) on Highway 1 between the Cassiar Tunnel and 216 Street. These restrictions will be in effect until Project completion in 2013.
- Shoulders may be closed or narrowed to ensure that construction crews remain safe while this necessary construction work takes place.
- Lane closures for the PMH1 Project are generally between 9 p.m. and 5 a.m. during weekdays; however, there are sometimes lane closures outside this period as well.
- Information about nightly lane closures is available on the PMH1 Improvement Project website: www.pmh1project.com.
- When necessary, construction crews will use concrete barriers and visual screening for additional safety and to minimize distraction for the travelling public.
- Between the Cassiar Tunnel and the Grandview Highway Interchange, motorists should exercise additional caution as shoulders may be slightly narrower than 0.5 metres in some areas.

For load widths wider than 3.8 metres, commercial vehicle operators should consider alternate routes so that the loads do not come into contact with pylons, equipment or personnel.

The following diagrams (next page) show lane widths for Highway 1 lanes before and during construction:

Mailing Address:

*Suite 1420 - 1111 West Georgia
Vancouver BC V6E 4M3*

Telephone: 778-783-1200

Facsimile: 778-783-1201

Info Line: 1-866-999-7641 (PMH1)

Port Mann/Highway 1 Project

Transportation Investment Corporation

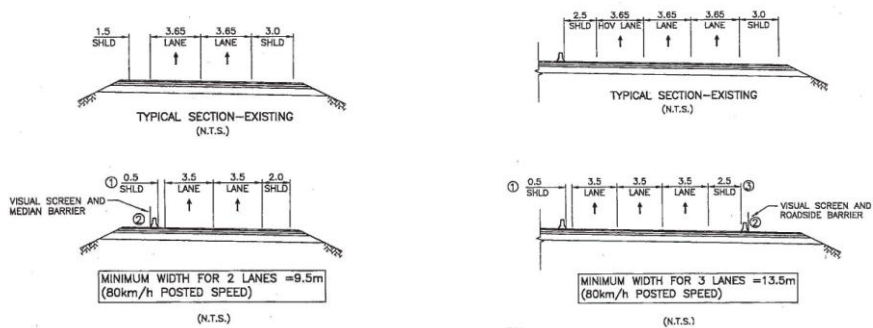

For general questions about load widths, please contact CVSE (Email: Commercial.Transport@gov.bc.ca or Call: (250) 952-0577). To schedule a wide load transfer or haul, please coordinate with the prime contractor Kiewit/Flatiron General Partnership (Email: devin.duranleau@pmh1.ca or Call: (604) 202-8647).

As crews continue to work along one of the busiest corridors in Canada, motorists are reminded to obey construction signs and construction zone speed limits, and to watch for flag persons. Please use caution, particularly at night.

We appreciate your continued patience as we complete this important highway improvement project.

Regards,



Steven Haywood
A/Deputy Director
Commercial Vehicle Safety and Enforcement
Ministry of Transportation and Infrastructure



Gerry Fleming
Project Director
Port Mann/Highway 1 Improvement Project
Transportation Investment Corporation